

# Newsletter

18.2021

Safety cable

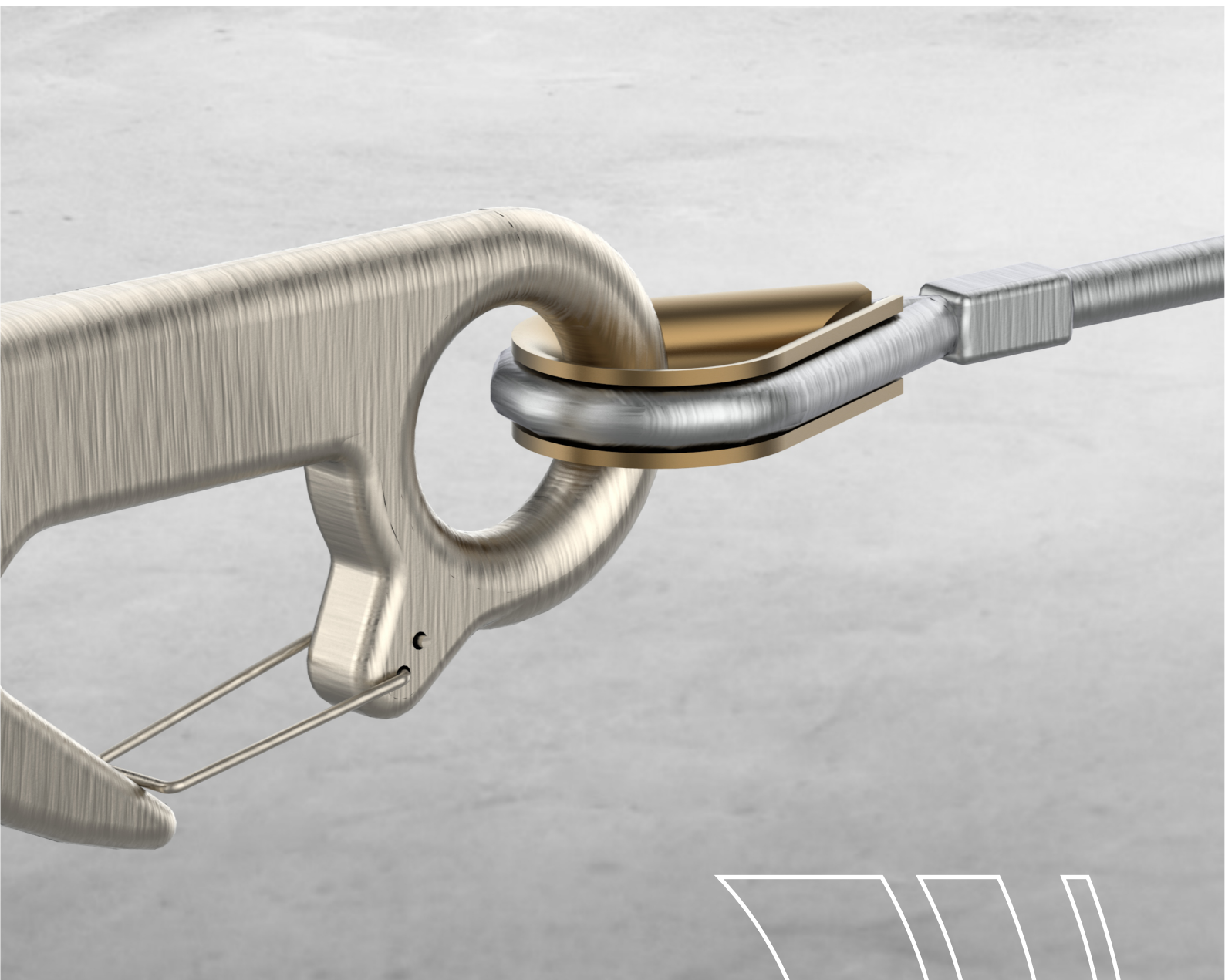

knott.pl



Dear Sirs,

The following publication aims to familiarize you with the role of the brakeaway rope, whose task is to force the trailer to brake when the hitch "disengages" from the ball of the towbar.

For this reason, it is extremely important to properly install the brakeaway rope on the hook of the towing vehicle to allow it to function properly.

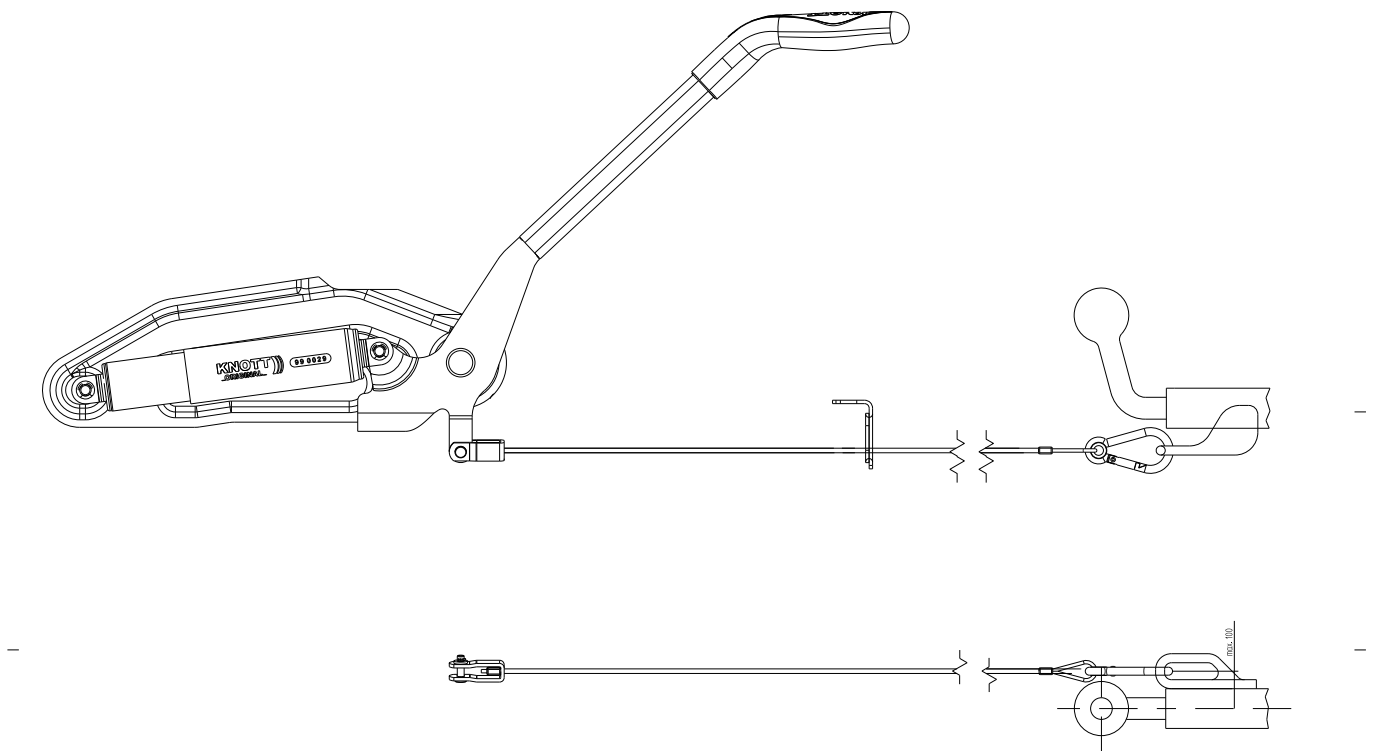

The above shows the correct connection of the security cable

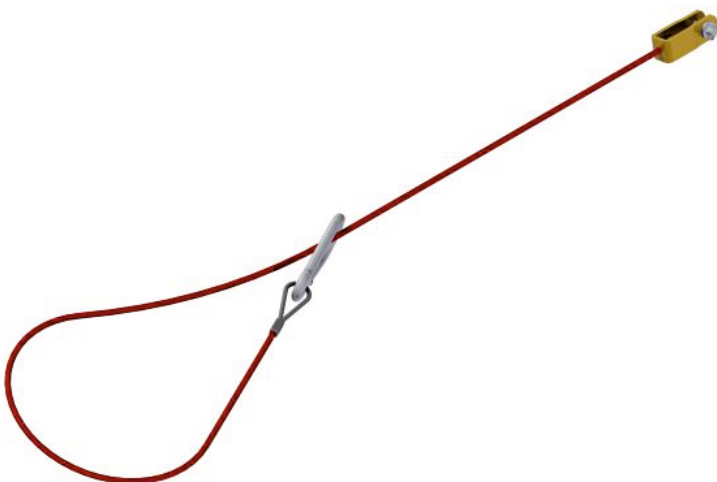

The lanyard must not release the force transmitted by the towing vehicle until a minimum breaking load of  $F = 5000\text{N}$  is achieved.

In addition, the maximum breaking load of  $7500\text{N}$  must not be exceeded. The handbrake lever must be in the braking position after the cable breaks.

For unbraked trailers with a drawbar with adjustable hitch height, we offer a stronger version of the securing cable for which we have increased the breaking force to 15,000 N. Thanks to this, it is possible to use a cable for special trailers, for which the breaking force should be higher due to the specificity of the trailer.

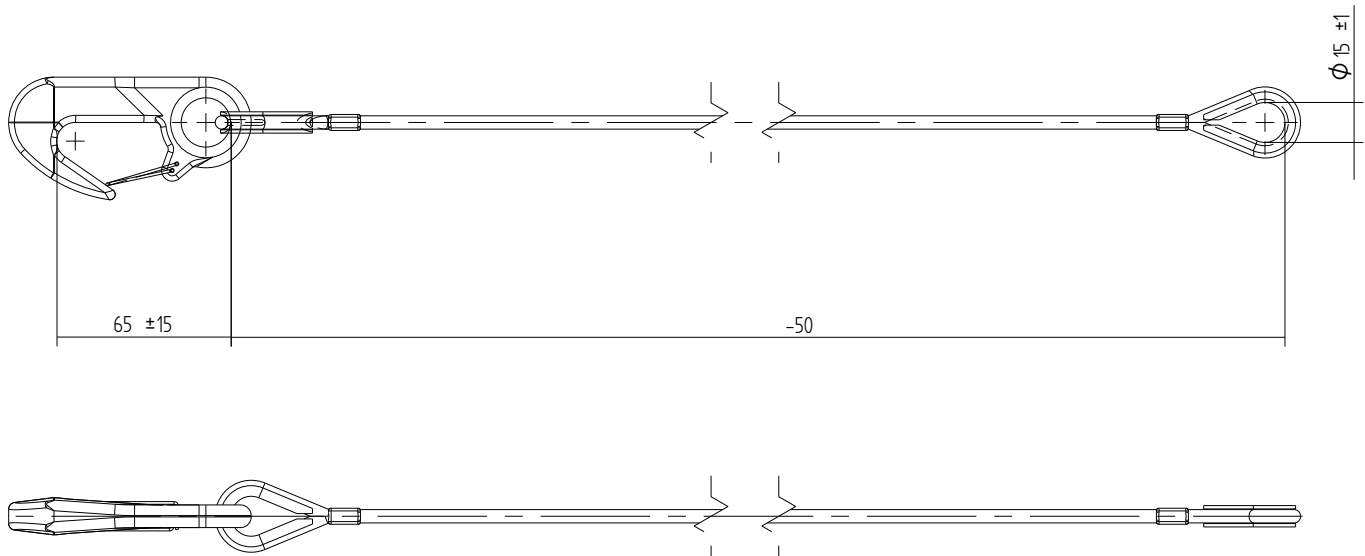

Art. Nr. 203514.001 - L-1000  
Art. Nr. 203514.002 - L-2000

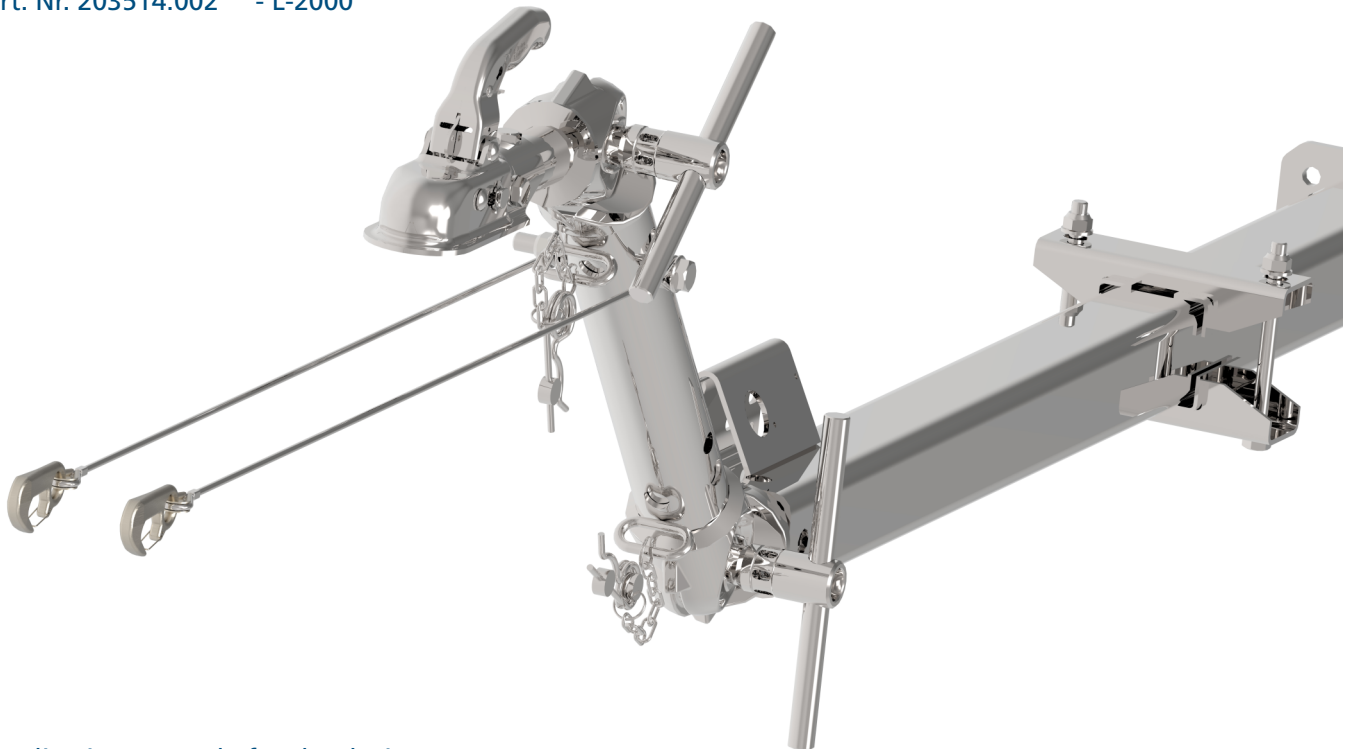

Application example for the device KDVV 7,5 A8  
Art. Nr. 6G0020.XXX

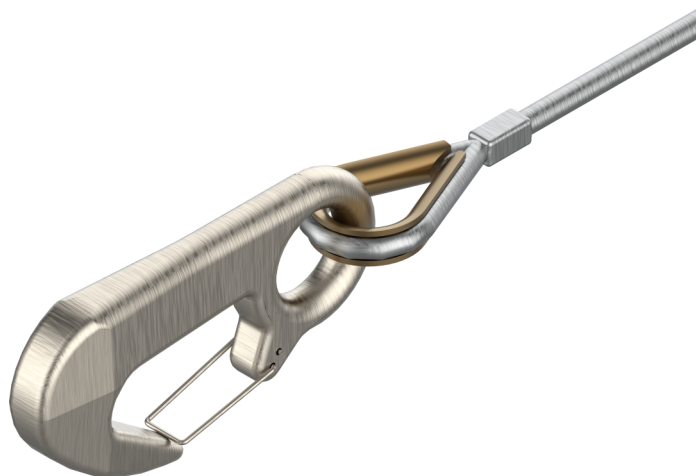

The presented security links are only an example of the links offered. In case of specific requirements, we recommend contacting the sales department representatives, who will be happy to advise you and help you choose a line that meets your expectations.

Below we present the brakeaway rope for the brake lever of the overrun device, which comes in several dimensions.

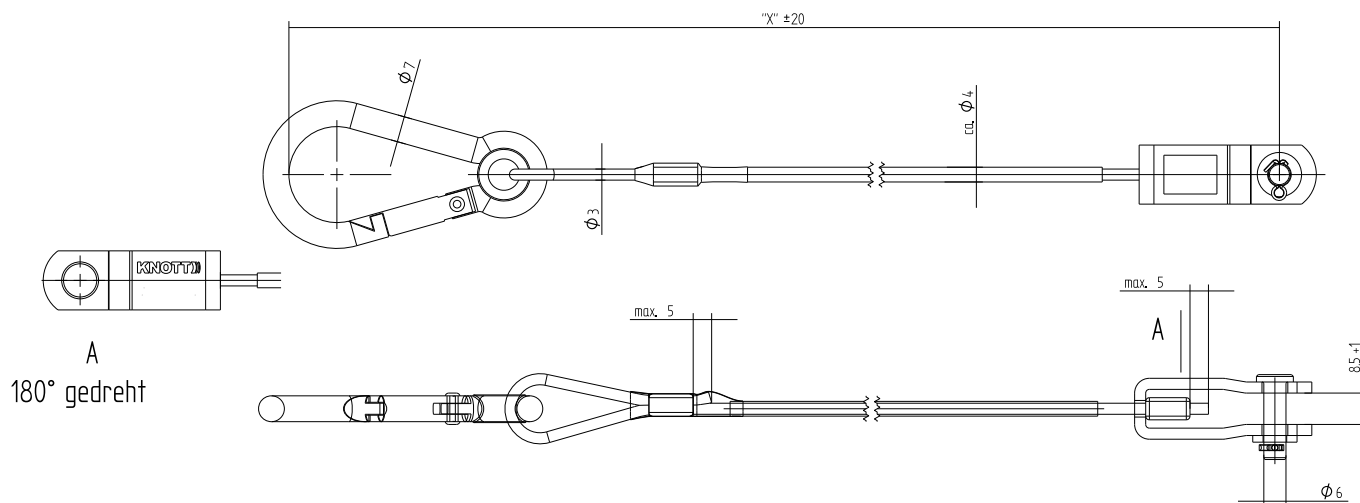

Art. Nr	Nazwa
203202.001	Breakaway rope 1055 mm
203202.002	Breakaway rope 1200 mm

Detailed information about the products is provided by the Trade Department of KNOTT Sp. z o.o.

KNOTT Sp. z o.o.

63-011 Pławce  
 Zdziechowice 100  
 tel. 61 287 60 00  
 fax 61 287 60 01  
 info@knott.pl  
[www.knott.pl](http://www.knott.pl)

