

for industrial trucks.

In the world of forklifts and industrial trucks used in logistical applications, individually tailored brakes offer the ideal solution for maximum reliability coupled with economy. Knott can draw on decades of experience in the development and production of brakes for use in this sector. We are working constantly on the development of new bespoke solutions and innovations which excel in meeting the needs of even the most complex applications.



The Knott Group – global competency

The member companies of the Knott Group design, develop, produce and market braking systems for commercial and off-highway vehicles together with running gear components for trailers. Production is sited at numerous locations in various countries and is undertaken strictly in accordance with stringent standards of quality.



Competent, one-to-one consulting and outstanding product quality are characteristic of all the companies within the Group.

All around the globe, we maintain delivery logistics, service and parts supply dependably and on a very high level.

Austria

Knott Handelsges. m.b.H.
Vienna
Phone +43 1 71422 22
e-mail: at@knott-group.com

Czech Republic

Knott CZ s.r.o.
Hustopec
Phone +420 519 322 321
e-mail: cz@knott-group.com

Finland

Autoflex-Knott Oy
Helsinki
Phone +358 95 52 250
e-mail: fi@knott-group.com

Germany

Knott GmbH
Eggstaett
Phone +49 8056 906 0
e-mail: de1@knott-group.com

Knott GmbH
Regenstau
Phone +49 9402 9317 0
e-mail: de2@knott-group.com

Knott Sales GmbH
Paderborn
Phone +49 5254 805 780
e-mail: de3@knott-group.com

Great Britain

Knott-Avonride Ltd.
Burton upon Trent, Staffs.
Phone +44 12 83 53 15 41
e-mail: uk1@knott-group.com

Knott-Avonride Ltd.
Maesteg, South Wales
Phone +44 16 56 73 91 11
e-mail: uk2@knott-group.com

Hungary

Autoflex-Knott Kft.
Kecskemet
Phone +36 76 48 15 15
e-mail: akk@knott-group.com

Knott-Technik-Flex Kft.
Cegléd
Phone +36 53 318 377
e-mail: tec@knott-group.com

Italy

Knott S.p.A.
Pian di Macina (Bo.)
Phone +39 05 16 51 64 45
e-mail: it@knott-group.com

Poland

Knott Sp. z o.o.
Pławce
Phone +48 61 287 60 00
e-mail: pl@knott-group.com

Romania

Knott Frâne Osii S.R.L.
Bucharest
Phone +40 722 38 30 90
e-mail: kro@knott-group.com

Russia

Autoflex S.R.L.
Salonta-Bihor
Phone +40 259 37 34 95
e-mail: aro@knott-group.com

OOO T.D. Autoflex-Knott
Moscow-Obukhovo
Phone +7 495 961 33 17
e-mail: ru@knott-group.com

Serbia

Knott-Autoflex Yug d.o.o.
Becej
Phone: +38 121 81 37 55
e-mail: yu@knott-group.com

Slovakia

Knott spol. s r.o.
Modra
Phone +421 33 690 25 11
e-mail: sk@knott-group.com

USA

Knott Brake Company
Lodi, Ohio
Phone +1 33 09 48 01 44
e-mail: kbc@knott-group.com

Autoflex Knott, Inc.
Fox Lake, Wisconsin
Phone +1 920 928 68 75
e-mail: aus@knott-group.com

From the specialist in custom-designed brakes and braking systems



Brakes for industrial trucks: Tailored to individual customer requirements

Performance, durability, reliability:
Brakes for all payload categories



www.knott-group.com



We make your brake

Knott GmbH
Obinger Strasse 15 · Postfach 20 · D-83125 Eggstaett · Phone: +49 80 56 / 906-0 · Fax: +49 80 56 / 906-103
Gutenbergstrasse 21 · D-93128 Regenstau · Phone: +49 94 02 / 93 17-0 · Fax: +49 94 02 / 93 17-99
info@knott.de · www.knott.de

www.knott.de



We make your brake

1000e P095.02.2010..8

Custom-tailored brakes from the specialist.

Knott may claim with some justification to be THE specialist in brakes and braking systems for all kinds of forklift. Because at Knott, every brake is developed in cooperation with the customer precisely to meet the needs of the specific truck requirements and work load. The type of application, environmental conditions and the duty demands made on the truck in question alone decide the design principle, the structure and the performance of the brake or braking system. Knott's specific field of specialist expertise lies in the production of medium to small brake lot size volume.



Hydraulic simplex drum brake 200x30 with automatic adjuster

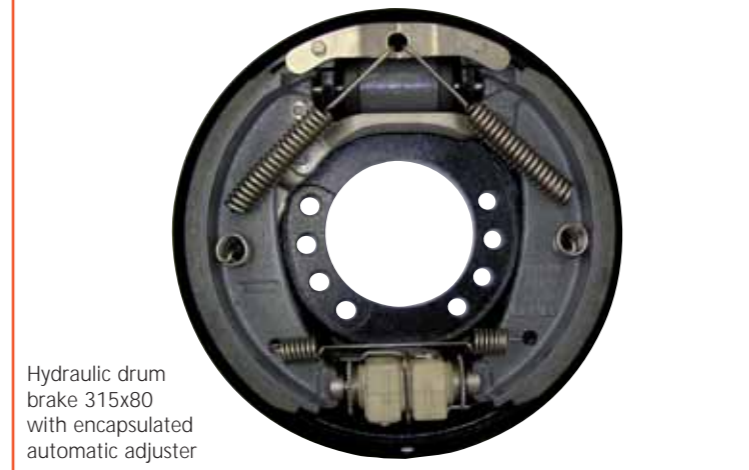

Hydraulic drum brake 315x80 with encapsulated automatic adjuster



Cam-operated wet multi disc brake 120x55



Steering brake stub with two fixed caliper 4x40 brakes



Hydraulic fixed caliper 4x85 brake



Spring-applied sliding caliper brake FSG 110 with carrier bracket

Knott brakes adapt perfectly to the special requirements of industrial trucks, ensuring impressive performance in terms of

- high duty capacity
- consistent output
- high braking efficiency and operator braking refinement
- long service life
- exemplary ease of maintenance functions

The long service life and high quality of Knott braking systems make a major contribution to the safety and economy of any truck in which they are installed.



The forklift success model: This reliable drum brake has been proven 100,000 times over, in anything from a 1-ton to a 12-ton capacity fork lift, in a wide range of variants and adaptations – precisely tailored every time to the specific customer needs.



Knott monitors and controls every step along the way: in-house design, in-house prototype construction, in-house testing and in-house production

All kinds of brake systems from a single source

We provide objective advice, because we are able to select the best braking principle for each application. On this basis, we tailor a unique, precisely adapted brake for each individual customer.

Knott develops and produces the following brake types:

- Disc brakes (fixed and sliding caliper)
 - Hydraulic
 - Pneumatic
 - Mechanical
- Drum brakes
 - Hydraulic
 - Pneumatic
 - Mechanical
- Encapsulated wet multi disc brakes
 - Hydraulic
 - Pneumatic
 - Mechanical
- All designs can be used as service or parking brakes.
- Other designs on request



Ultra-compact design plus extreme efficiency: The 130x28 cam brake from Knott

Top performance in compact format

This Knott development is unique in more ways than one: As a parking or emergency brake, this small drum brake achieves braking torque levels unlike any other of its size. It is mounted at the fork lift transmission, actuated by Bowden cable and is able to reliably brake and hold any truck with a total payload of up to 8.8 tons on inclines of up to 15%. At the purchase, installation and commissioning stage: This is a brake which minimizes costs and effort like no other

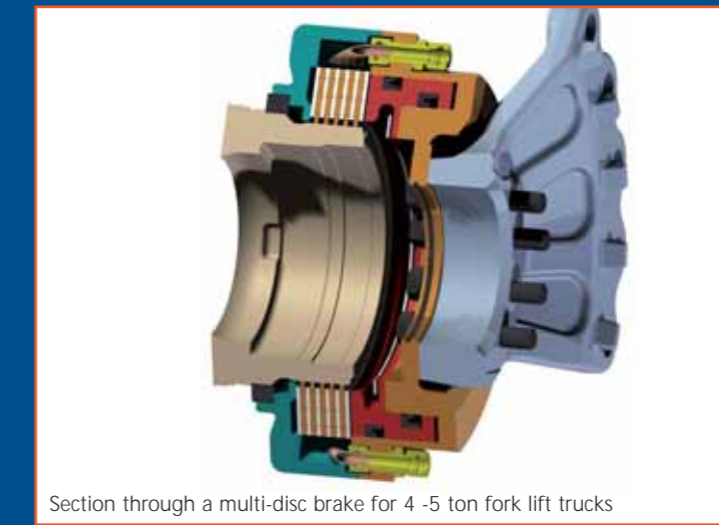

Section through a multi-disc brake for 4-5 ton fork lift trucks

Same axle, different brake: The option of high-end or low-cost!

A major manufacturer of forklift trucks previously fitted its 4 to 5-ton gas / diesel forklifts with drum brakes. These are permanently integrated into the axle design. However, the extreme operating demands resulted in premature wear. Knott stepped in to design a complete wet brake unit within an enclosure which fitted precisely into the existing mounting space created by the axle. This solution allows fork lift customers to choose between a simpler or a more premium quality braking system. The manufacturer does not incur any additional expense, as all dimensions and fixing points of the axle could be retained irrespective of the integrated braking concept.

Strong partners: A few examples from the Knott customer list



Renowned names from the global material handling sector worldwide speak for themselves- and for Knott.

Knott brakes: proven in every lifting capacity class

